



### SPECIFICATIONS

Access door shall be a watertight door as manufactured by Karp Associates, Inc., Melville, NY. Door lid shall be fabricated with 1/4" aluminum diamond plate designed to support a H20 loading (without impact) with a maximum deflection of 1/150th of span. Frame shall be a 1/4" extruded aluminum channel-type frame with a 1/8" neoprene cushion and continuous anchor flange and a 1-1/2" drain coupling welded to the underside. Door shall open 90 degrees and automatically lock in that position with a stainless steel hold open arm with a red vinyl grip. Door lid shall be equipped with a recessed lift handle. Hinges shall be all stainless steel and attached with tamperproof fasteners. All hardware shall be grade 316 stainless steel. Doors shall have a mill finish with a bitumastic coating applied to the exterior of the frame to prevent hydrolysis with concrete. Doors shall be equipped with a stainless steel spring assist which shall provide a smooth and controlled operation when opening and closing door. Operation will not be affected by temperature. Door shall be equipped with a stainless steel slam lock with cover plug and removable handle. Door shall be furnished with a peel-off protective cover to protect finish from concrete splatter. Underside of lid shall have visibility tape applied for safety. Manufacturer shall guarantee material and workmanship for a period of ten years.

OPTIONS: Skirting to depth of slab, fiberglass insulation, safety chains & posts.

LOCK OPTIONS: staple for padlock, recessed hasp, keyed deadbolt lock, pentahead lock.

MODEL	"A"	"B"	"C"	"D"	WT.
FD2424AHNS	24"	24"	24"	5.5"	45 lb
FD2430AHNS	24"	30"	24"	5.5"	50 lb
FD2436AHNS	24"	36"	24"	5.5"	55 lb
FD2442AHNS	24"	42"	24"	5.5"	60 lb
FD3030AHNS	30"	30"	31"	6.5"	55 lb
FD3036AHNS	30"	36"	31"	6.5"	60 lb
FD3048AHNS	30"	48"	31"	6.5"	70 lb
FD3636AHNS	36"	36"	37"	6.5"	70 lb
FD3648AHNS	36"	48"	37"	6.5"	85 lb
FD4242AHWS	42"	42"	44"	7.5"	95 lb

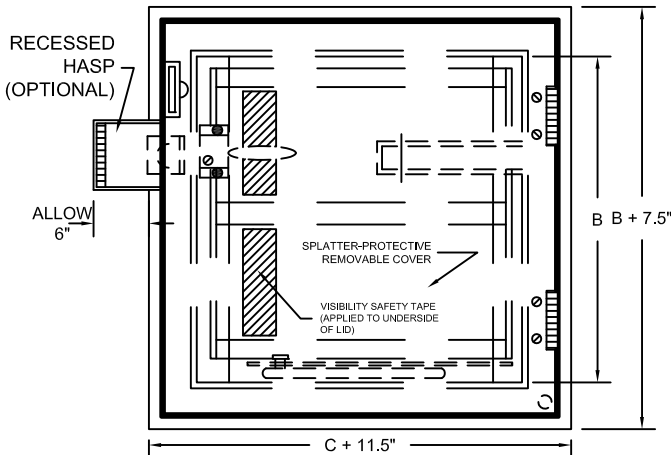

DATE

### PROJECT DATA

Project Name:
Architect:
Contractor:
Agent/Customer Name:
Tagging Instructions:
Special Instructions:

### PROJECT SCHEDULE

Qty.	H	W	No. of Latches	Finish	Remarks

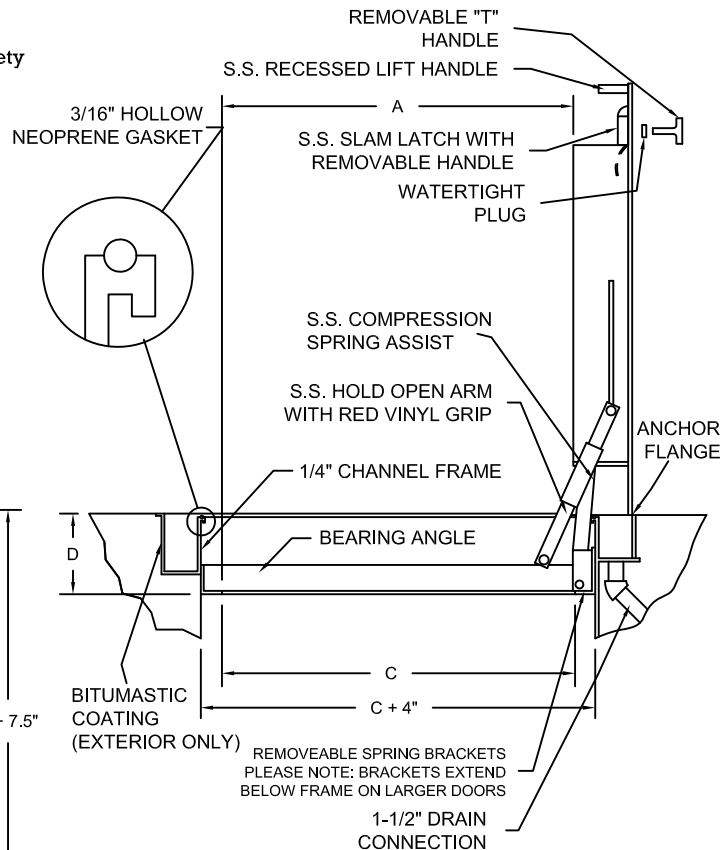

**NOTE:**  
ALUMINUM H20 DOORS ARE FOR OFF-STREET LOCATION ONLY.



Made with Union Labor